

MOTOMAN GP12

Handling & General Applications
with the GP-series



The MOTOMAN GP12 is a fast and precise 6-axis industrial robot with a payload capacity of up to 12 kg. With a reach of 1440 mm and a high repeatability of ± 0.02 mm, it is ideally suited to assembly tasks, but also universal handling tasks, CNC machine tool tending or packaging. Its streamlined modern industrial design minimizes the space requirements at the installation site.

The prepared routing of the supply lines through the hollow arm enables optimal integration of the grippers or sensor systems, often dispensing with the need for an external media package. This reduces also interference contours.

With the MOTOMAN GP12 and numerous functions of the MOTOMAN YRC1000 controller or the compact MOTOMAN YRC1000 micro controller a wide range of applications can be realized. In conjunction with the conventional teach pendant, this robot is a reliable mechanical engineering partner. With the innovative operator control concept of the Smart Pendant, it provides an excellent point of entry into industrial automation.

As standard, the MOTOMAN GP12 is designed with the high protection classification IP67 (wrist). Other variants (e.g. with food-compatible grease in the food industry, special anti-corrosion coating for applications in aggressive ambient conditions, or as a cleanroom version) are optionally available.

KEY BENEFITS

- Fast and powerful
- Compact and flexible
- Large working range: 1440 mm
- Reduced interference contours due to optimized design
- Simple commissioning and maintenance

Controlled by
YRC1000

Controlled by
**YRC1000
micro**

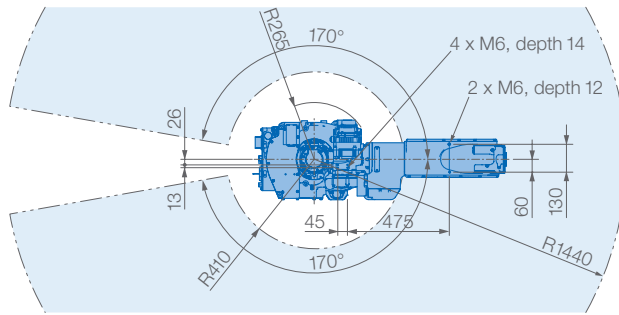
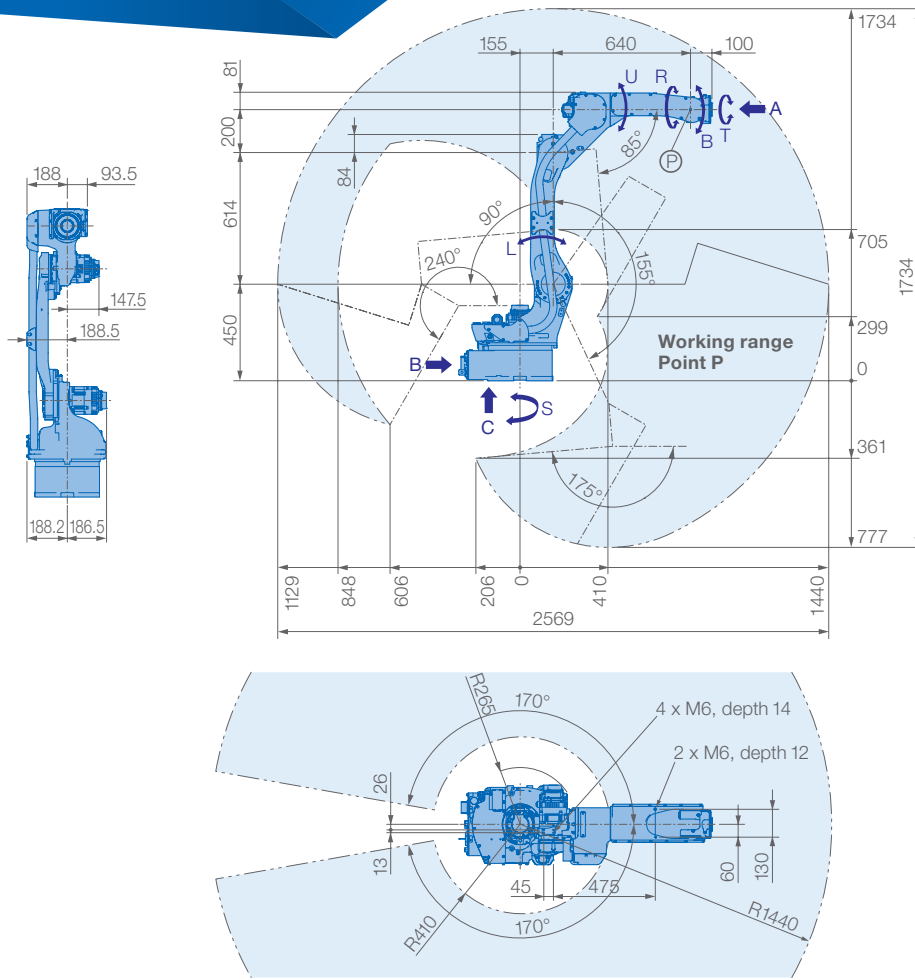

Prevent interaction of the robot with:

- Corrosive gases, liquids or explosive gases
- Exposure to water, oil or dust
- Excessive electrical noise (plasma)

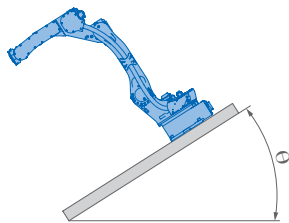

Allowable wrist load

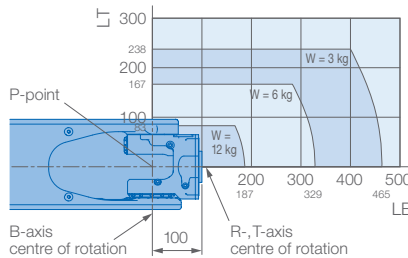

View A

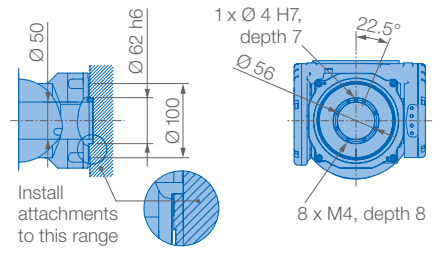

View B

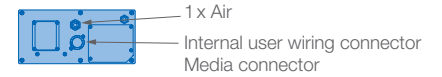

View C

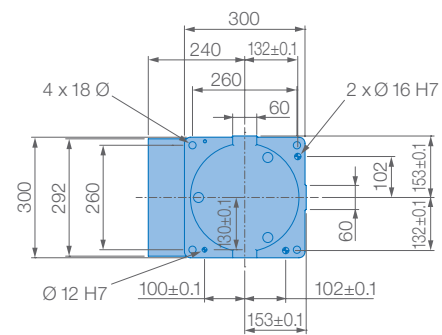

Mounting options: Floor, ceiling, wall, tilt*

Protection class Version YR-1-06VX12-A00
Standard: Main axes (S, L, U) IP54, wrist IP67

Protection class version YR-1-06VX12-C00:
Main axes (S, L, U) IP65, wrist IP67

* tilt with condition of angle – see table below

| Robot installation angle θ [deg.] | S-axis operating range [deg.] |
|--|--------------------------------------|
| $0 \leq \theta \leq 30$ | ± 170 degrees or less (no limit) |
| $30 < \theta \leq 35$ | ± 60 degrees or less |
| $35 < \theta \leq 45$ | ± 45 degrees or less |
| $45 < \theta$ | ± 30 degrees or less |

Specifications GP12

| Axes | Maximum motion range [°] | Maximum speed [°/sec.] | Allowable moment [Nm] | Allowable moment of inertia [kg · m ²] | Controlled axes | |
|------|--------------------------|------------------------|-----------------------|--|-----------------------------|--------------|
| S | ± 170 | 260 | – | – | Max. payload [kg] | 6 |
| L | +155/–90 | 230 | – | – | Repeatability [mm] | 12 |
| U | +155/–85 | 260 | – | – | Max. working range R [mm] | $\pm 0.02^*$ |
| R | ± 200 | 470 | 22 | 0.65 | Temperature [°C] | 1440 |
| B | ± 150 | 470 | 22 | 0.65 | Humidity [%] | 0 to +45 |
| T | ± 455 | 700 | 9.8 | 0.17 | Weight [kg] | 20 – 80 |
| | | | | | Power supply, average [KVA] | 150 |
| | | | | | | 1.5** |

* Conforms to ISO 9283 ** Varies in accordance with applications and motion patterns **Note:** SI units are used for specifications.